

ASLOC-T Biometric Terminal



1. ASLOC-T

The ASLOC-T is a terminal that provides a facial biometric solution to time and attendance and access control. It is designed specifically for harsh environments to withstand heavy duty, intensive use within the construction industry. However, we do have full control over hardware design and manufacture, meaning a variant can be produced to mould and fit client requirements. The system can be a stand-alone unit or built within another structure, such as gate, stand or turnstile. The ASLOC-T is a compact device, which can be easily customised to suit the business it is being implemented into.

ASLOC-T is a multi-token solution, with multiple communication and interface ability. It utilises the very latest fanless intel processing technology, running silently and efficiently. The terminal uses PSI's latest facial recognition hardware, which has been implemented and approved throughout numerous industries from biometric UK airport security, bank back office/secure site access, medical patient identification and time and attendance in some of the largest construction organisations within the United Kingdom.

PSI have supplied exceptionally reliable facial recognition imaging hardware to industry for the last 10 years, within highly secure environments. Our biometric solutions verify over 500,000 individuals every day, which equates to over 5 people per second every day.



The ASLOC-T consists of several features to aid secure access control and time and attendance. These features include: -

- Accurate and reliable facial recognition access control. The biometric terminal utilises near infra-red (NIR) lighting hardware technology to accurately recognise facial features. The hardware can produce an image set within a fraction of a second that can detect a very detailed 3D face, considering any shadowing or shading, lighting levels and spectral reflection (meaning the system is tolerant of persons wearing glasses). This means noticeably clear and highly detailed images can be captured independent of ambient light conditions, such as low light or direct sunlight.
- The camera illumination technology can account for the environment to give a detailed image of the subject. Our lighting technology can adjust to give accurate image exposure levels. All these features are processed very quickly due to the compact but powerful processing ability of the terminal. Illumination technology has been designed to be fully eye safe for a subject from any distance.



- The terminal incorporates bright touchscreen technology and is designed to have an optional card reader fitted. With facial recognition, ASLOC-T has a minimum of two-factor authorisation. Alongside facial recognition, a touch screen input pin code can be incorporated and/or an optional card reader can bring the ability to include a RFID access card token that the reader can detect once registered.
- A token is presented to the system, which is assigned to a user that triggers user verification. The token may be a pin number or swipe card. This has the advantage of allowing very high number user access, as the user database is token indexed. This high security mode allows tens of thousands of individuals to be accurately and quickly verified.

- The optional card reader can be fitted below the screen, the furthest point from the camera, designed specifically to avoid verification obscuring the image being produced by the camera at the time of reading the token.
- The camera can read QR or barcodes (software dependent). This could be an alternative or additional token to present to the terminal for access control. Alongside facial recognition, this option could give a multi token contactless solution to the device.
- The ASLOC-T utilises the latest interfacing, processing and camera technology. The unit is a fully windows 11 compliant device, with a dedicated TPM 2.0 module.

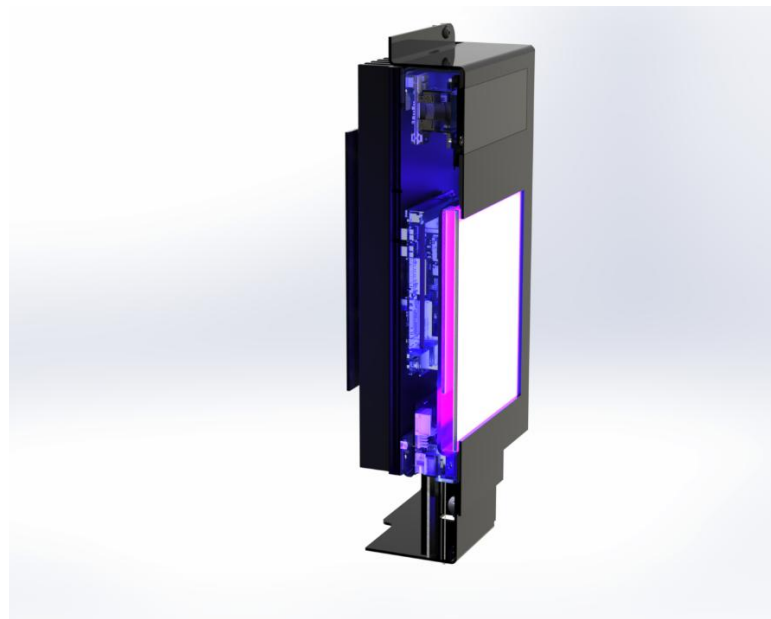

- The biometric terminal is designed to be power efficient, 20W in operation. It employs a low voltage input to power the system. The unit is designed to be automotive voltage supply compliant, running off a 12V DC supply, making the terminal advantageous for mobile applications and for powering the terminal in remote areas without mains power.



- The system produces little heat and is a fanless, solid state unit. The terminal is silent.
- The ASLOC-T includes RS485/RS232 communication ports. These ports can communicate directly to an external device such as an encrypted lock or actuator, which can be installed on a turnstile and/or security door. A direct hardware connection can be made to volt free contacts ensuring the terminal can directly operate the contact via its biometric and multi token verification. This enables a biometric and multi verification secure access solution to the barrier control, ideal for authorised personnel only environments. Additionally, if the lock is placed on the secure side of the barrier, the entire linked system becomes an extremely high-grade security device that is controlled by the ASLOC-T.
- The size and interface of the unit makes easy integration into a kiosk, turnstile, wall or similar structures.
- A 10.1" high resolution touchscreen gives the terminal an embedded operator user interface that can be employed by a user wearing gloves.
- ASLOC-T is built and designed to be a long-life product with easily maintainable components and service access. PSI's biometric solutions have proven reliability in various environments.

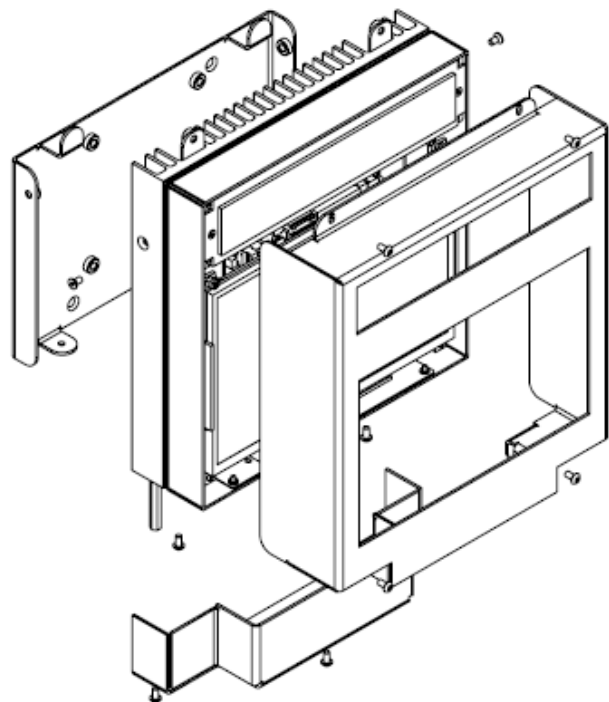

1. Specifications

Processor choice:	Intel® Core™ i3-1115G4 (up to 3.0GHz, dual-core, 6M Cache, TDP: 28/15/12W) – Default fitment Intel® Core™ i5-1135G7 (up to 2.4GHz, quad-core, 8M Cache, TDP: 28/15/12W) - optional
RAM:	Single 260-pin DDR4 SODIMM Socket, Supports Up to 32GB DDR4 3200MTs SDRAM (non ECC only) Default fitment 8GB
Expansion/Storage:	1 x M.2 Type M 2280 (with 1 x PCI-e Gen4 x4) 1 x M.2 Type B 3042/3052/2242 (with SATA and USB2.0, USB 3.0, 1 x M.2 Key E 2230 support WiFi module (1 x PCI-e x 1 & USB 2.0 Signal)) Default fitment 512GB SSD on M.2 Type M 2280
TPM	Onboard NuvoTon NPCT750AADYX support TPM 2.0, co lay Infineon SLB9670VQ2.0 & Z32H330TC-SQN-755
Graphics:	Intel® Tiger Lake UP3 SoC Processor integrated
Display:	10.1" TFT-LCD, 1280 x 800, 16:10 WXGA, 1000 nits, LVDS, 16.2M colours, anti-glare and resistive touch
Power Supply Voltage	+12V DC - +24V DC in
Operating Power	20W
Operating Ambient Temperature	-10°C to 50°C
Connectivity:	3 x USB 3.2 Gen 2x1 (one used for Camera) 5 x USB 2.0 1 x RS232/422/485 5 x RS232 2 x LAN RJ-45, Dual Gigabit Ethernet 1 x 2.5GbE, 1 x 1GbE 2 x DP++, Triple Display possible when including LVDS
Hardware OS	Windows 11, Linux
Cooling	Fanless, heat sink cooling, silent operation.

Near Infrared Camera

Resolution	1280 x 960
Pixels	1.2 Mega Pixels
Frame Speed	44fps
Technology	High Dynamic Range (HDR)
Spectral Response	NIR with 850nm centre wavelength
Interface	USB 3.0
Output	12-bit
Illumination	Near Infra-Red (NIR)

Approvals

- CE compliant
- UKCA Compliant
- RoHS compliant
- WEEE compliant
- Eye Safe
- Exempt from Low Voltage directive (Under 50V)
- Can be produced to be an IT device approved to be used in a medical environment.

2. Dimensional Drawings (mm)

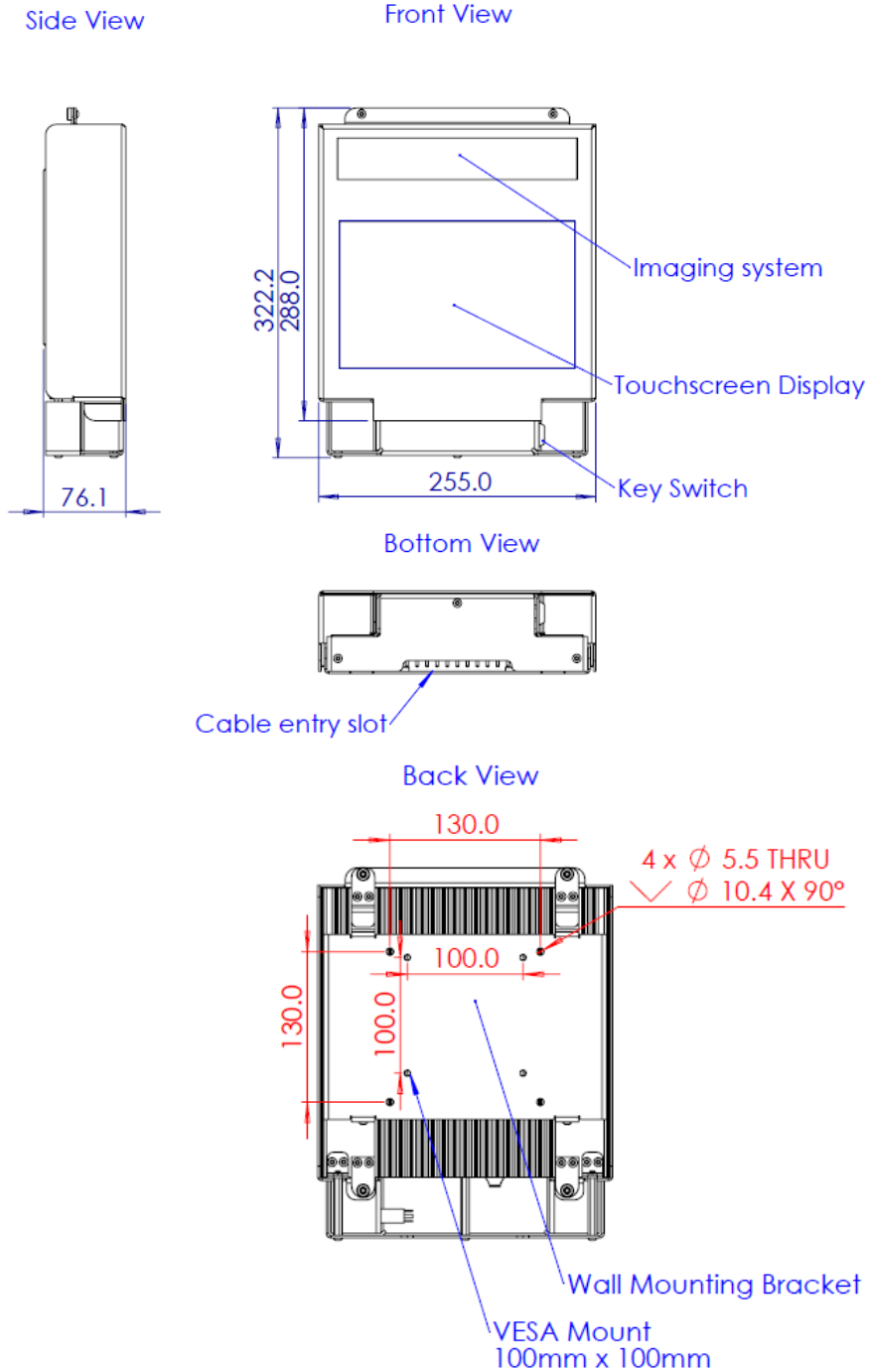

3. Copyright, and Confidentiality Statement

This document is a strictly confidential communication to and solely for the use of the recipient. No part of this documentation or the products and firmware described in it may be reproduced, transmitted, transcribed, stored in a retrieval system or translated into any language in any form or by any means (except documentation kept by the purchaser for backup purposes) without the express written permission of Perception Sensors and Instrumentation Limited. Specifications and information contained in this document are furnished for informational use only and can be subject to change at any time.

Copyright © Perception Sensors and Instrumentation Limited.

All documents in the accompanying documentation pack, except for third-party documentation, are Copyright © Perception Sensors and Instrumentation Limited.

